

Operation Manual

For the

Sageon Battery Monitor

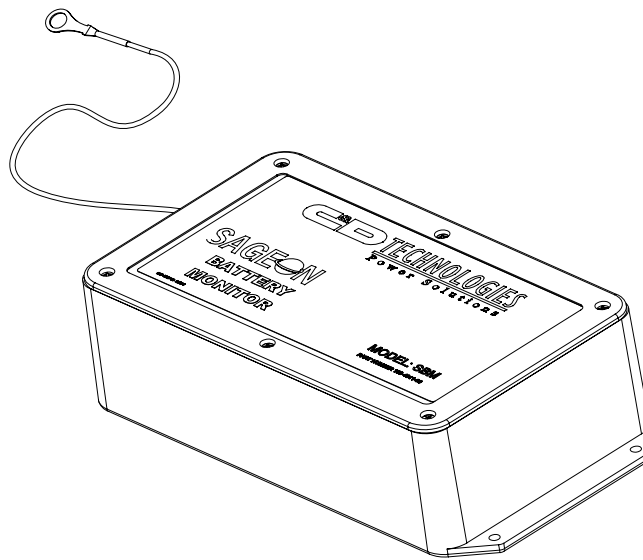

C&D Technologies, Inc.
Integrated Power Systems,
Power Systems Division
65 Industrial Park Road, Dunlap, TN 37327
Customer Service, Voice: (800) 440-3504
Customer Service, Fax: (423) 949-3647
Field Service: (800) 299-3907
Web site – <http://www.cdpowercom.com>

RECEIVING INSTRUCTIONS
and
GENERAL EQUIPMENT INFORMATION

Please Note: For your protection, this product manual should be read and thoroughly understood before unpacking, installing, using, or servicing the described equipment.

C&D Technologies, Inc., STANDBY POWER Division¹ presents all equipment to the delivering carrier securely packed and ready for transport. Upon acceptance of the equipment from us, the delivering carrier assumes responsibility for its safe delivery to you. Once you receive the equipment, it is your responsibility to document any damage to the equipment that was sustained during transport to you and to file your claim with the carrier promptly and accurately.

PACKAGE INSPECTION

Examine the shipping container for any visible damage: punctures, dents, and any other signs of possible internal damage.

Describe any damage or shortage on the receiving documents and have the carrier's representative sign his/her full name.

EQUIPMENT INSPECTION

Promptly upon receipt of shipment, open the container and inspect the contents for damage. Unpack the shipment carefully to avoid scratching or otherwise marring the exterior finish. Be careful not to discard any included equipment, parts, or manuals. If damage is detected, call the delivering carrier to determine appropriate action. The carrier may require an inspection.

IMPORTANT: If damage is detected, save all shipping material for the carrier's representative!

If damage is detected, also notify C&D Product Support. C&D will determine if the equipment should be returned for repair. If it is determined that the equipment should be returned to C&D, ask the delivering carrier to send the packages back to C&D at the delivering carrier's expense. Be sure that the equipment is properly packaged for shipment.

¹ Throughout the remainder of this manual "C&D" will mean "C&D Technologies, Inc., STANDBY POWER Division."
PM990-4209-00, Issue 3
MAY 2006

SAGEON BATTERY MONITOR MANUAL

If repair is necessary, C&D will invoice you for the repair so that you may submit the bill to the delivering carrier with your claim form.

It is your responsibility to file a claim with the delivering carrier. Failure to properly file a claim for shipping damages may void warranty service for any physical damages later reported for repair.

NAMEPLATE

A C&D product is identified by a nameplate that includes model number, part number, and serial number information, as appropriate. Please include this information, shown in italic in the label drawing below, in all correspondence with C&D. A sample nameplate is shown below.

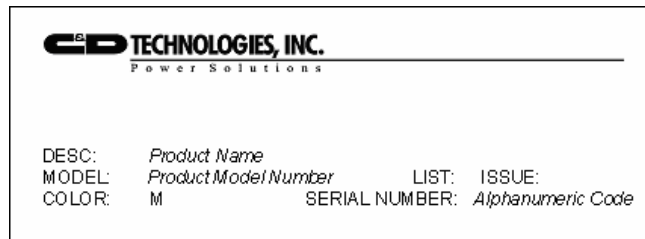

INITIAL SETTINGS

All equipment is shipped from the factory *fully inspected and adjusted*. Read the technical reference or product manual before installing or making any adjustments.

ISSUE HISTORY

Issue	Page(s) Altered	Description	Date
1	All	Original Release; PM 990-4209-00, ECN-14561	RC 02-2004
2	Most	Revised and Up-dated Manual, ECN-15079	RC/KN/MF 05-2005
3	ALL	SEE ECN 15560	MCM 6/6/06

QUALIFIED PERSONS

The equipment described herein should be installed, configured, operated and serviced only by qualified persons thoroughly familiar with:

- This Product Manual and any documents referenced in this manual
- Current revisions of applicable national (e.g. National Electrical Code) and local codes
- Applicable on-site procedures, licensing requirements, and safety requirements

DOCUMENT SUMMARY

This product manual provides installation, operation, maintenance, and troubleshooting procedures for the C&D Sageon Battery Monitor. It consists of seven chapters with drawings. The drawings supplement the provided descriptions and procedures.

Thank you for purchasing the Sageon Battery Monitor. We at C&D are proud of the quality of our products and welcome any suggestions to further improve our design to fit your needs.

PROPRIETARY AND CONFIDENTIAL

The information contained in this product manual is the sole property of C&D Technologies, Inc. Reproduction of the manual or any portion of the manual without the written permission of C&D Technologies, Inc. is prohibited.

DISCLAIMER

Data, descriptions, and specifications presented herein are subject to revision by C&D Technologies, Inc. without notice. While such information is believed to be accurate as indicated herein, C&D Technologies, Inc. makes no warranty and hereby disclaims all warranties, express or implied, with regard to the accuracy or completeness of such information. Further, because the product(s) featured herein may be used under conditions beyond its control, C&D Technologies, Inc. hereby disclaims and excludes all warranties, express, implied, or statutory, including any warranty of merchantability, any warranty of fitness for a particular purpose, and any implied warranties otherwise arising from course of dealing or usage of trade. The user is solely responsible for determining the suitability of the product(s) featured herein for user's intended purpose and in user's specific application.

© Copyright C&D Technologies, Inc. 2003, 2005

Sageon and SageView are trademarks of C&D Technologies, Inc. Other trademarks are the property of their respective owners.

TABLE OF CONTENTS

1. INTRODUCTION	1
1.1. MAIN FEATURES OF THE SBM	1
2. SPECIFICATIONS	2
3. INSTALLATION OF SAGEON BATTERY MONITOR	2
3.1. PREPARING THE BATTERY FOR CONNECTION TO THE SBM.....	2
3.2. INSTALLING THE BOARD	3
3.3. BATTERY CELL LEAD CONNECTION TO THE SBM BOARD.....	4
4. DIP-SWITCH SELECTION OF CELL VOLTAGES	13
5. DIP-SWITCH SELECTION OF ADDRESS	13
6. SYSTEM SETUP FOR SBM	13
6.1. RELATIONSHIP BETWEEN “SBM BATTERIES” AND “NUM BATTERIES”	13
6.2. BATTERY CONFIGURATION IN 48V AND 24V SYSTEMS.....	14
6.3. BATTERY CURRENT SENSOR ENABLE/DISABLE	15
6.4. BATTERY MONITOR ON/OFF.....	15
7. OPERATIONAL SETUP FOR SBM	15
7.1. SCU MENU STRUCTURE FOR SAGEON BATTERY MONITOR	15
7.2. FREQUENCY OF MEASUREMENT.	16
7.3. LOW/HIGH CELL VOLTAGE ALARM	16
7.4. CELL VOLTAGE DEVIATION ALARM.....	17
8. PROCESSING OF CELL VOLTAGE INFORMATION	17
8.1. STORAGE OF BATTERY DISCHARGE INFORMATION.....	17
8.2. INFORMATION AVAILABLE VIA THE SCU VFD DISPLAY	17
8.3. INFORMATION AVAILABLE ON THE PC	18

1. Introduction

The C&D Technologies Sageon Battery Monitor (SBM) is an add-on module for the Sageon Control Unit (SCU). It is used to monitor individual cells of a battery during float or equalisation operation, or during a discharge. Each SBM unit is capable of monitoring up to 24 cells or monoblocks. Up to four SBM units can be used to monitor up to 4 battery strings of 24 cells or monoblocks each.

Using the ability of the SCU to communicate to a remote or local PC, cell voltage data accumulated during a discharge can be transferred to a PC and saved. The cell voltages can also be viewed in real time when the SCU is connected to a PC. The Sageview software that is running on the PC can display the cell voltage data in various convenient formats to ascertain the state of health of batteries.

In addition to the real time or historical representation of the data on the Sageview, the cell voltages can also be observed in real time on the SCU VFD display.

In the event that the battery behaves in a way which is less than ideal during a test or actual discharge, a number of pre-programmed parameter levels are used to generate alarms which are annunciated on the SCU front panel by a LED and screen message and remotely via voltage free contacts or via the RS-232 communications port which can connect directly to a PC locally or remotely via a modem or Ethernet.

1.1. Main Features of the SBM

- Up to 24 cells can be monitored by a single SBM module. Cell voltage setting can be 2V, 4V, 6V and 12V.
- Up to four SBM boards can be connected to a single SCU.
- Individual cell voltages of a battery can be viewed on the SCU display in real time. The cell voltage rounded to the nearest 5mV (applies only to 2V range) is displayed together with the cell number and its percentage deviation from the average cell voltage of the battery.
- All the cell voltages can be displayed in a “Histogram” format on a local or remote PC using Sageview software for a very convenient and rapid visual indication of normal and deviant cells.
- The PC can display the real time cell voltages or cell voltages stored during a previous discharge. In this instance, a mouse driven slider bar is used to select at which point in the discharge to display the cell voltages.
- A line graph of cell voltage versus time can be selected as the PC display to observe the manner in which the cell voltages as a whole decreased during a discharge. It is also possible to select for all the cell voltages to be displayed (in different colours) or for a particular cell voltage to be displayed together with the average cell voltage as a function of time.
- As the SBM is permanently connected to the batteries, an automatic, daily or weekly down-loading of the steady state cell voltages for the different batteries in a system to a remote monitoring PC can be very useful for anticipating the state of health of the batteries

SAGEON BATTERY MONITOR MANUAL

- When desired, a discharge can be initiated either locally or remotely by triggering the rectifiers in the system into “battery discharge test” mode. In the mode the rectifier float voltage is set to a lower value which ensures that the batteries are carrying the load, but not too low so that in the event of battery failure during the test, the rectifiers will prevent the voltage from falling below the set voltage, which enable the load to continue functioning correctly. This test can be arranged to occur in non critical times. It is particularly useful if there has not been a recent discharge due to failure of the commercial AC supply.

2. Specifications

Battery configuration options (48V systems): 24Cell x 2V, 12Cell x 4V, 8Cell x 6V, 4Cell x 12V

Battery configuration options (24V systems): 12Cell x 2V, 6Cell x 4V, 4Cell x 6V, 2Cells x 12V

Maximum battery voltage: 75Vdc

Number of cells: 24 maximum per SBM

Number of strings per SBM: 1, 2, 3, or 4 depending on configuration (See section 3.3).

Cell Voltage selection (DIP switch setting on the board):

2V (max input: 3.33V)

4V (max input: 6.66V)

6V (max input: 10V)

12V (max input: 20V)

Note: “Cell” can mean both single battery cell or monoblock.

Accuracy: $\pm 0.5\%$ of measurement.

Drift for 1 year: $\pm 10\text{mV}$ at 0°C to 40°C

Resolution: 5mV per cell (2V, 4V, 6V range), 10mV per cell (12V range)

Sampling interval range for discharge log: 1 - 60 minutes

Power supply: from SCU ($\pm 15\text{V}$)

Maximum distance from SCU: 30 ft. combined cable length from SCU for all SBM's. If an SSM (Sageon Site Monitor) is used, it should have its communication cable terminated at the SCU interface board and not connected to any SBM.

3. Installation of Sageon Battery Monitor

3.1. Preparing the battery for connection to the SBM

SBM Battery Sense Leads are supplied with an internal $56\Omega/\text{PR}02$ resistor, as shown in figure 1. In the event of a short circuit, this resistor will act like a current limiting device/fuse, protecting the SBM and batteries from damage.

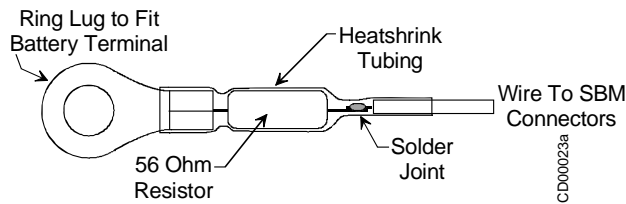

Fig. 1 Lead termination at battery cell.

To connect the sense leads to the SBM and to the battery cells:

CAUTION: DO NOT proceed if the battery string is being charged or discharged at a high rate. Continue only when the battery string is at float.

1. Note the battery configuration and select the appropriate figure from section 3.3 of this manual.
2. Pay particular attention to the polarity of the connections and insertion/removal of the J9 link.
3. Refer to the selected figure and measure the length of wire needed to reach from a terminal on an SBM terminal block to the indicated battery cell.
4. Select a battery sense lead and cut the wire to length. Strip the unterminated end 3/16".
5. Feed the stripped end of the wire through the large grommet of the SBM.
6. Connect the stripped lead to the appropriate SBM screw terminal on J2 or J3.
7. Connect the Ring Lug terminal to the appropriate battery cell terminal; make certain to re-torque the battery cell terminal bolt to the manufacturers specified torque requirements.
8. Repeat until the battery cells are wired to the SBM terminal block(s).
9. Repeat the above steps for each battery string.
10. Secure the wires to the PC Board's strain relief components using wire-ties. See Figure 2.

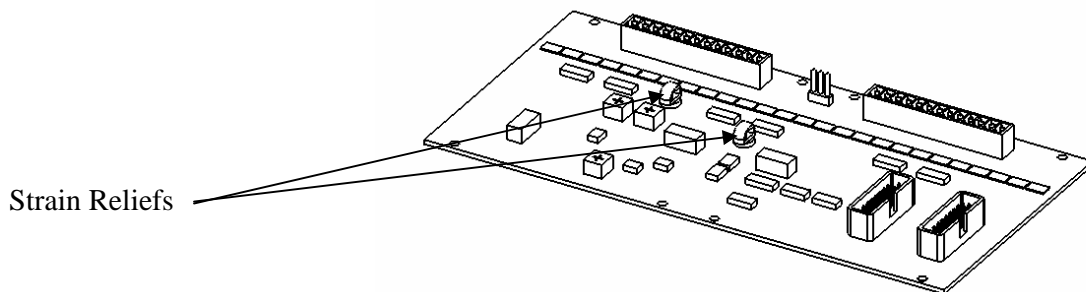

Fig. 2 Strain Relief locations.

The Ring Lug is connected onto the cell terminals. The other end of the wire is secured into the screw terminals. Details on how the cells connect to the SBM board are discussed in later sections.

3.2. Installing SBM

Generally, the SBM is located close to the batteries so that it is not necessary to run large number of wires for long distances. The 16-conductor ribbon cable connecting to the SCU can be up to 30 Feet long, but should be connected directly to the SCU, instead of connected at the end of another chain

SAGEON BATTERY MONITOR MANUAL

of peripherals. This helps reduce measurement errors. This connection can be achieved by using a 'daisy chain' ribbon where the one cable has connectors placed part way along its length as well as the ends.

Mount the SBM in an area protected from mechanical and electrical hazards. If the rack does not provide any holes or studs for mounting the SBM, use the following figure for drilling the mounting holes.

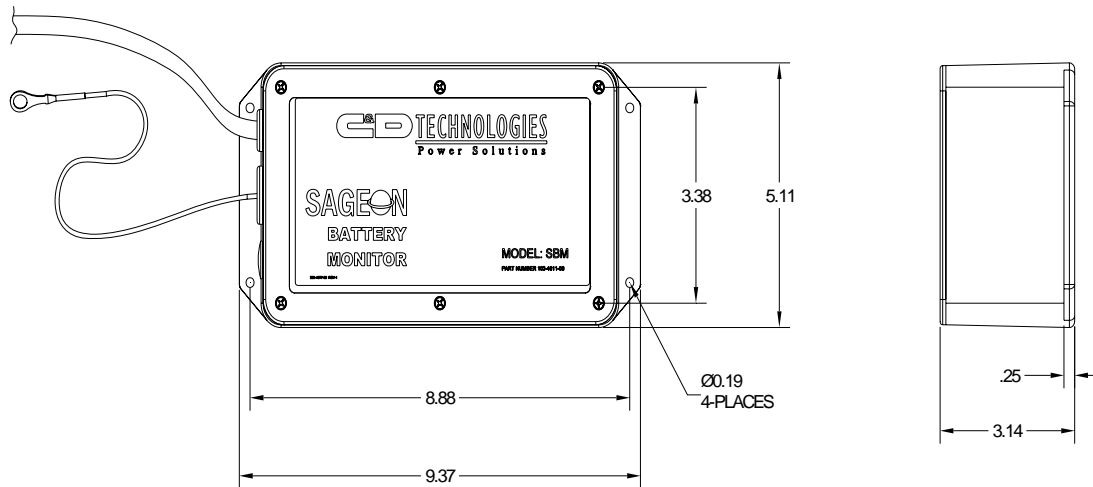

Fig. 3 SBM mounting hole locations.

3.3. Battery Cell Lead Connection to the SBM board

The battery cell sensing leads are terminated with the 13 position female terminal blocks. This plugs onto the connectors on the SBM board. How the cell voltage sense leads connect to the SBM board depends on the battery configuration. The following figures show the connection between the battery and the SBM board for different configurations of the battery. If more than 2 batteries are used in a particular configuration, simply repeat the connection method for batteries 3 and 4.

WARNING: Sense leads, which are connected to the battery string, pose a short circuit hazard. Each connection to the SBM should be made **BEFORE** attaching the ring lug terminals to the battery post. Cut and dress the supplied sense leads during installation. A wire label card is shipped with each SBM, use these labels to label the wires at the terminal end as well as the SBM end.

When connecting the battery sense leads, the lead should be dressed to the battery terminal **BUT NOT CONNECTED TO THE TERMINAL YET**. Next, the SBM end of the lead should be cut, stripped and inserted into the pluggable terminal block receptacle. Only after the terminal block end has been terminated should the ring terminal be attached to the battery bolt.

The battery bolt should be re-torqued to manufacturer's recommended torque when re-installing bolt.

NO-OX-ID is recommended on the battery sense lead ring lugs to minimize corrosion.

SAGEON BATTERY MONITOR MANUAL

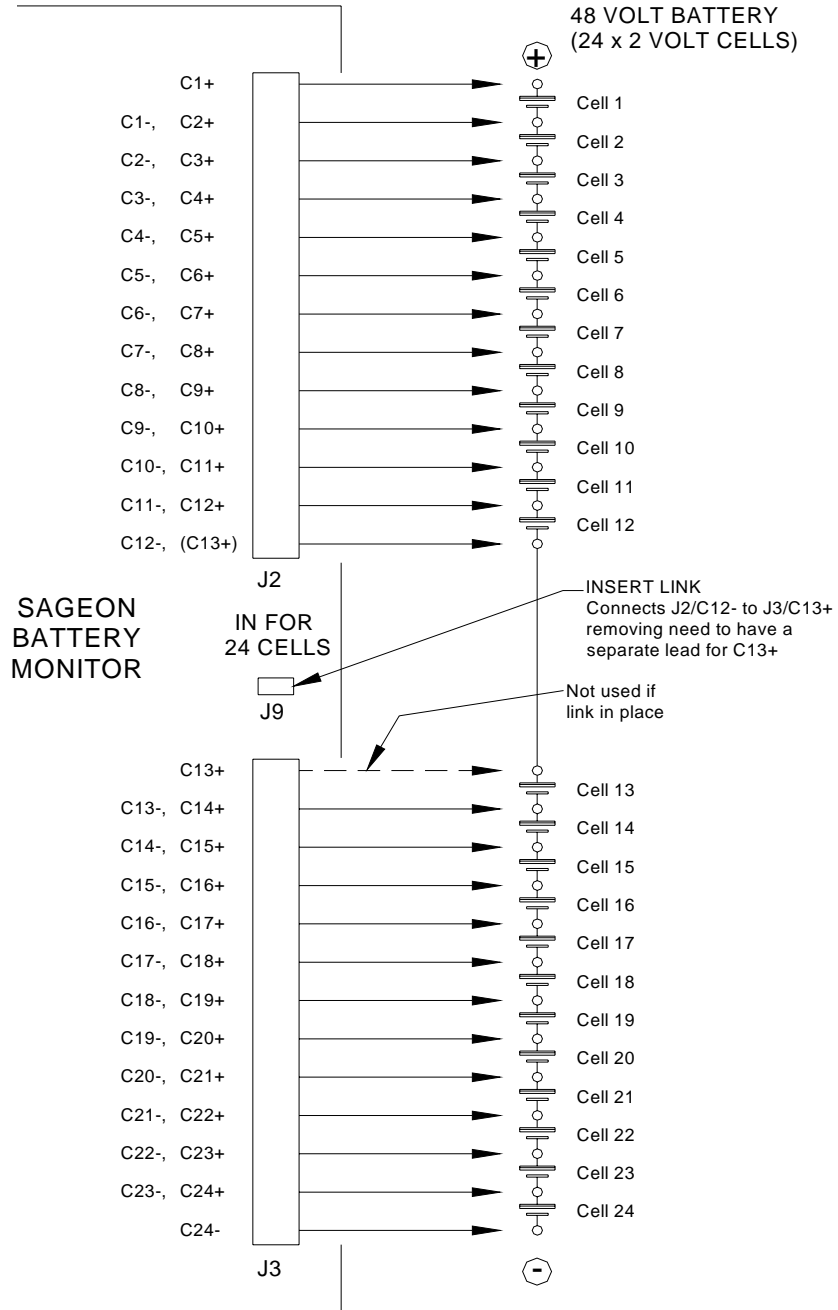

Fig. 4 SBM connections to a 48V (24 cell) battery string.

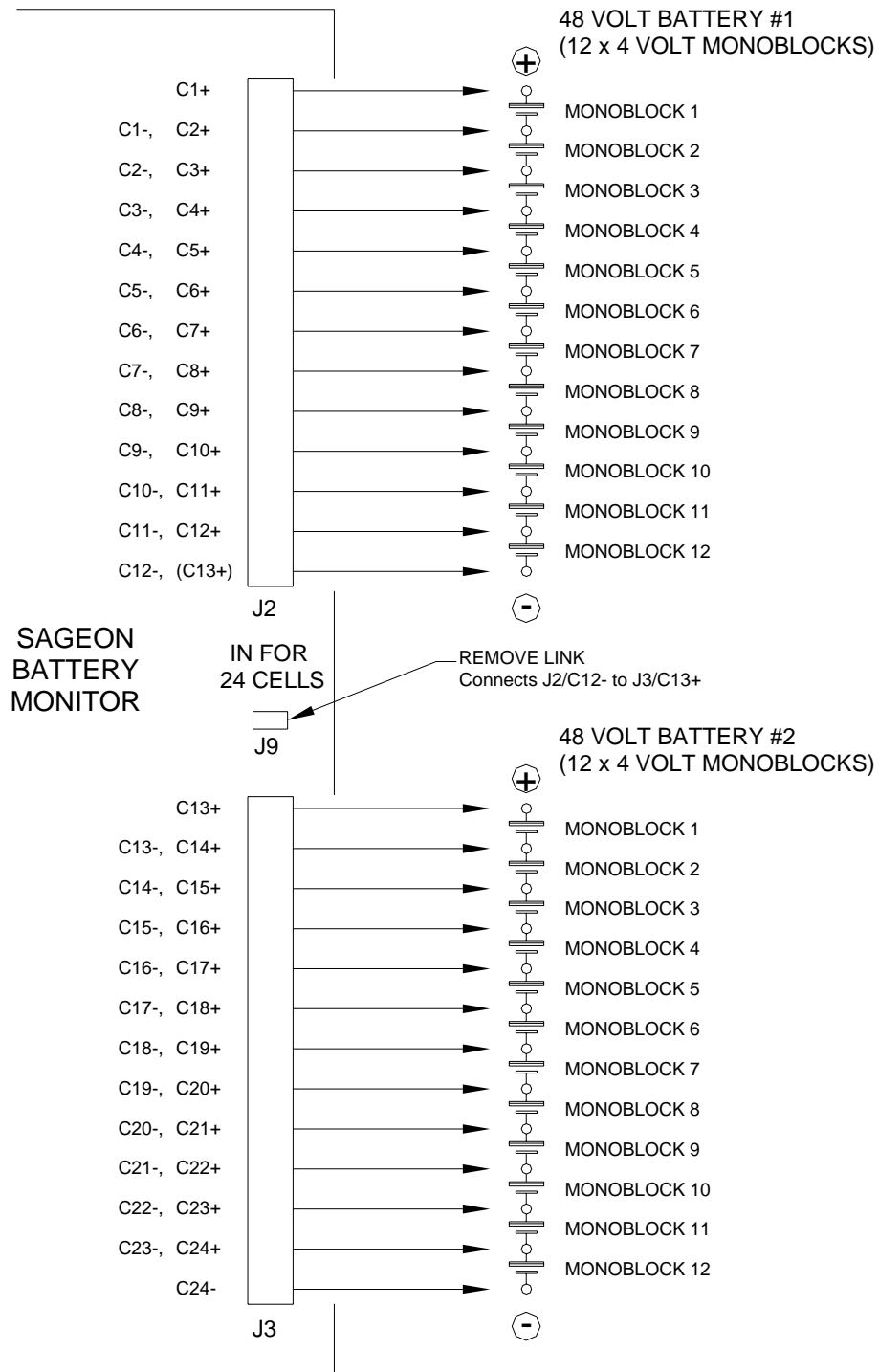

Fig. 5 SBM connections to two 48V (12 monoblock) battery string.

SAGEON BATTERY MONITOR MANUAL

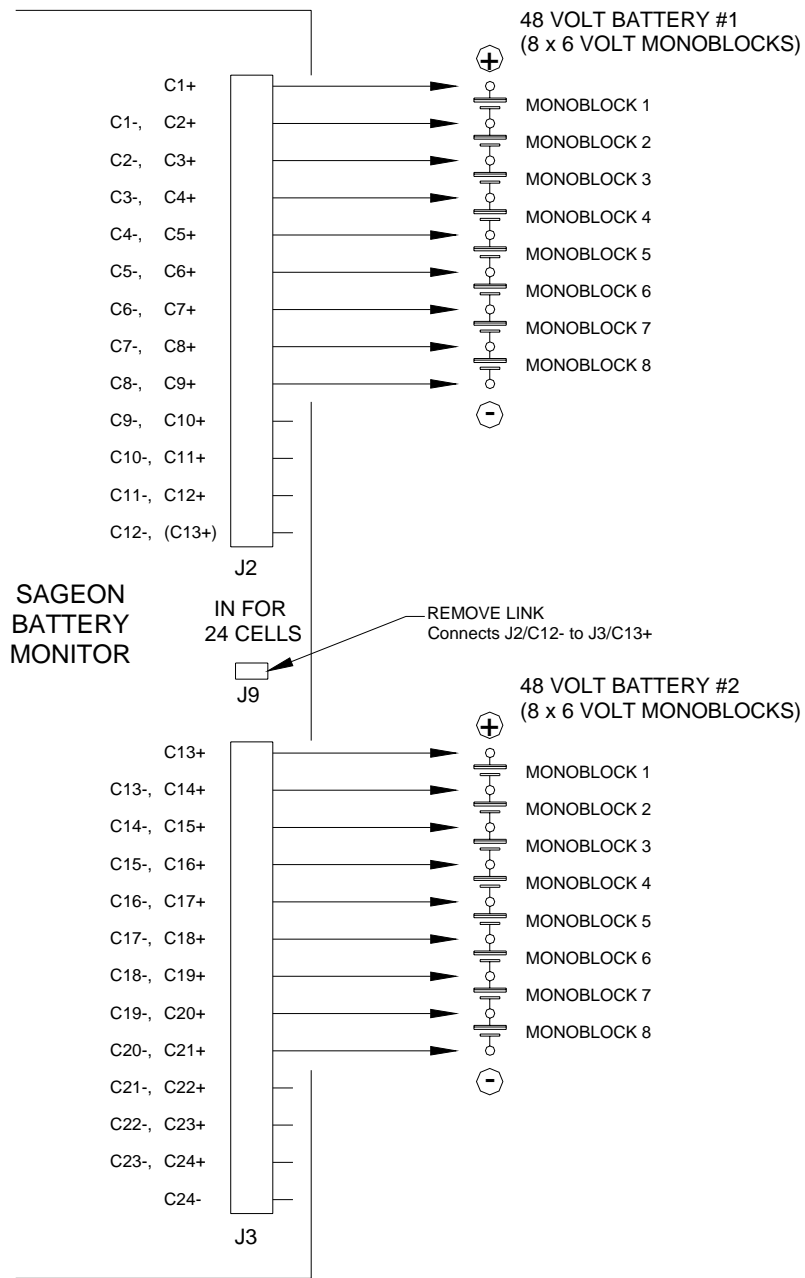

Fig. 6 SBM connections to two 48V (8 monoblock) battery string.

SAGEON BATTERY MONITOR MANUAL

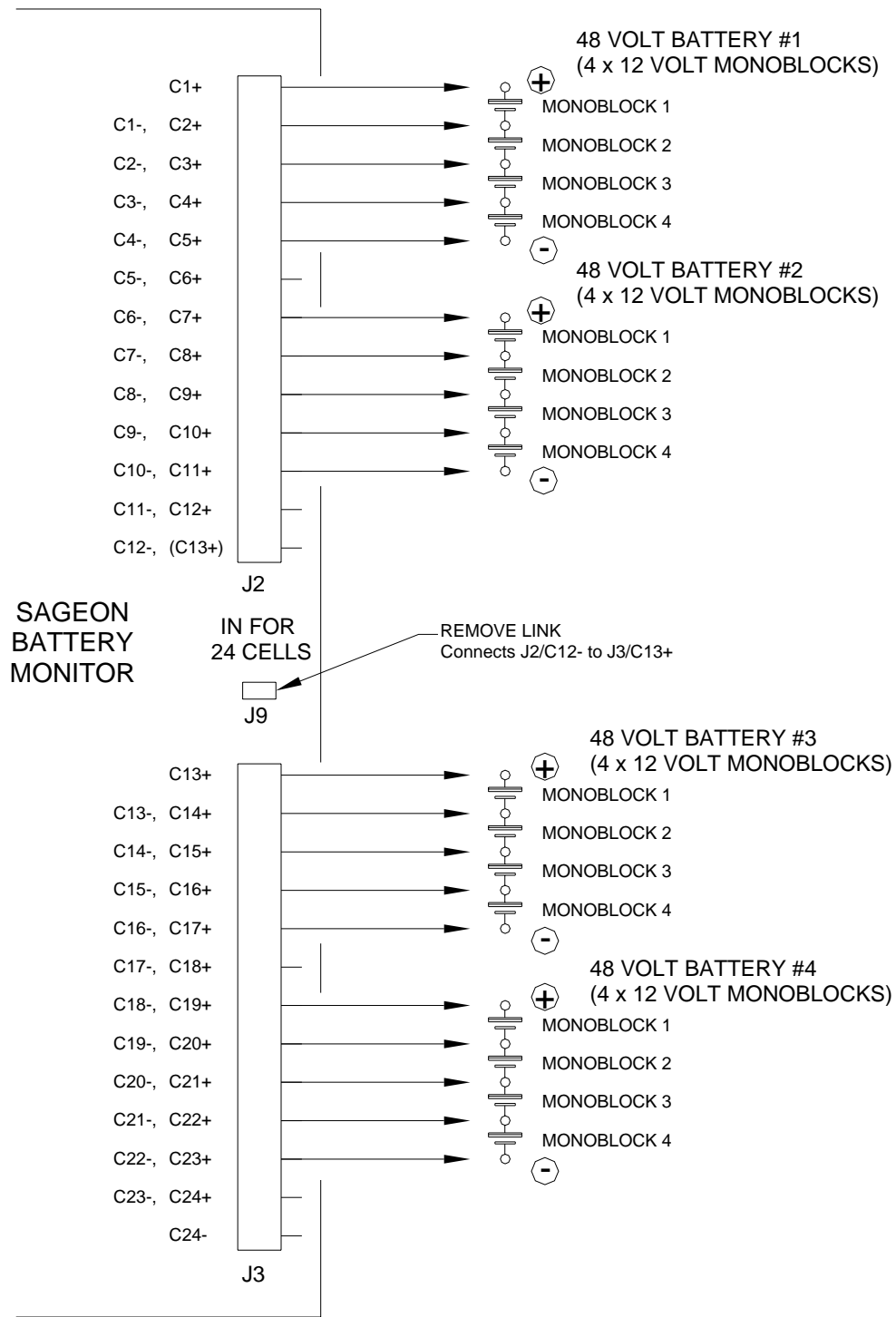

Fig. 7 SBM connections to four 48V (4 monoblock) battery string.

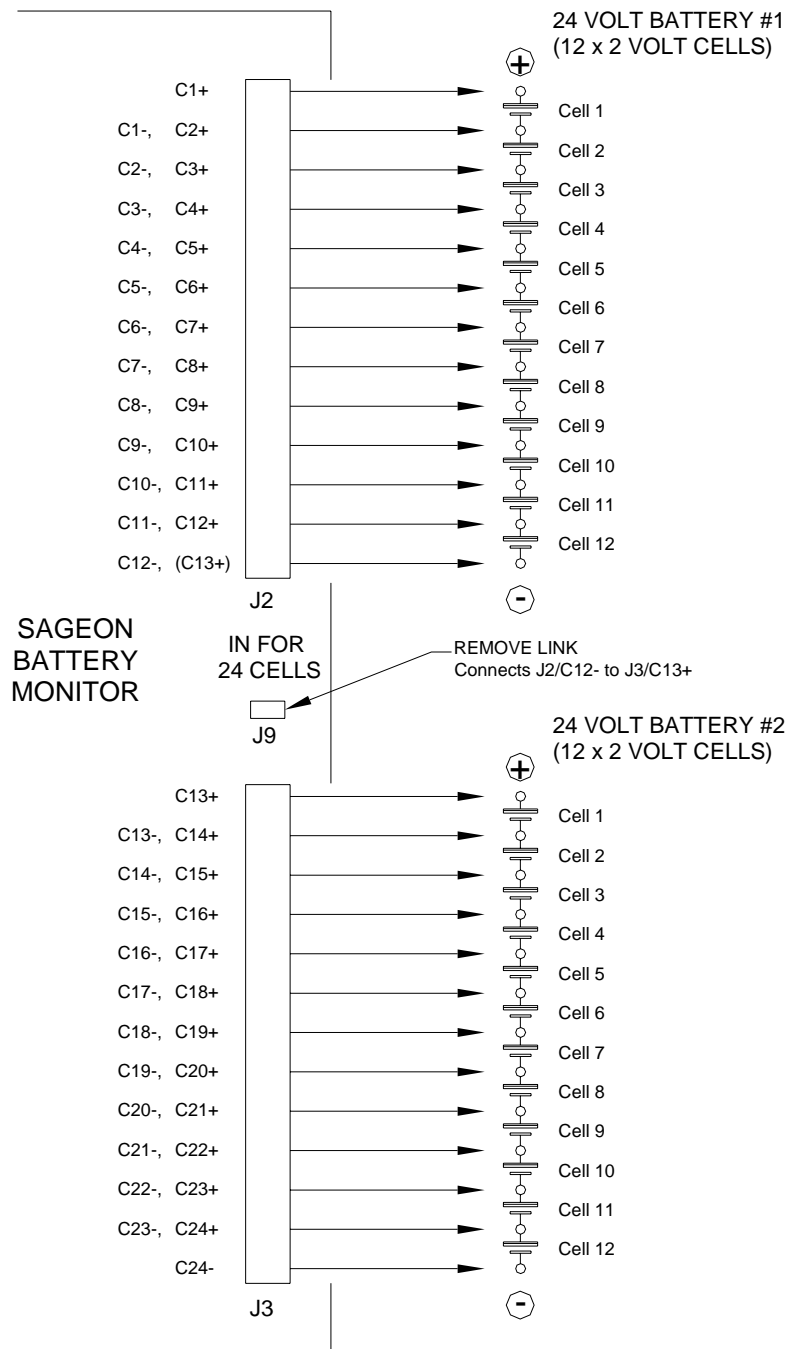

Fig. 8 SBM connections to two 24V (12 cell) battery string.

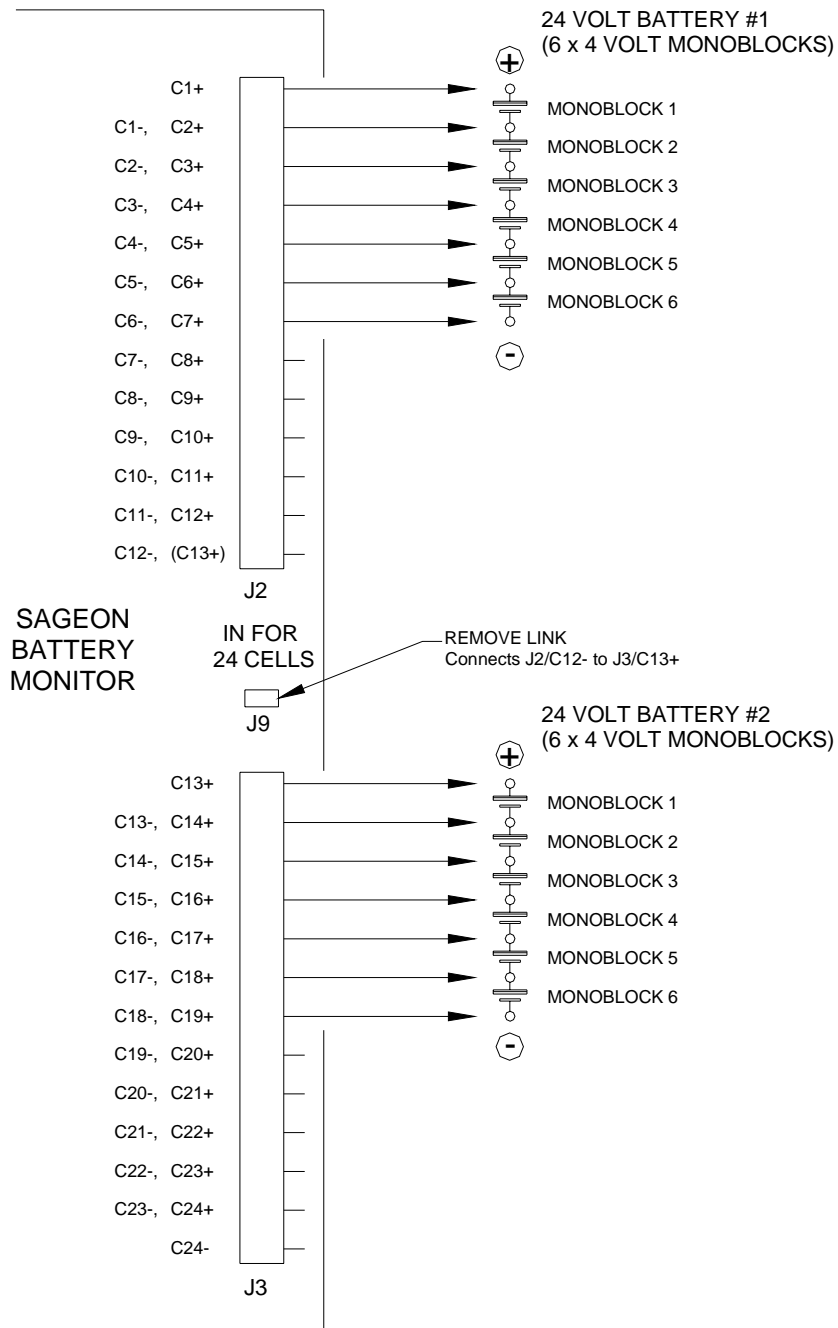

Fig. 9 SBM connections to two 24V (6 monoblock) battery string.

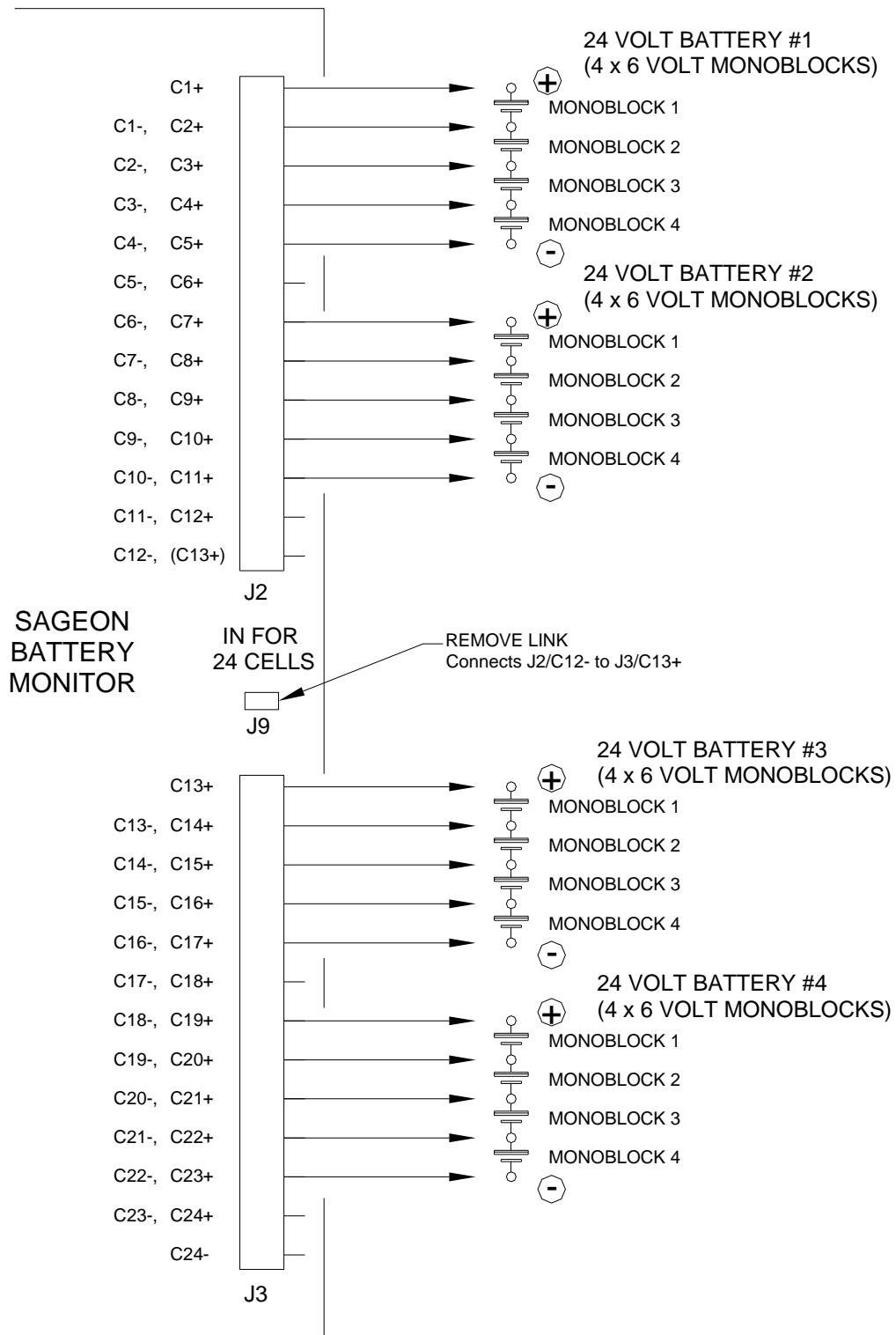

Fig. 10 SBM connections to four 24V (4 monoblock) battery string.

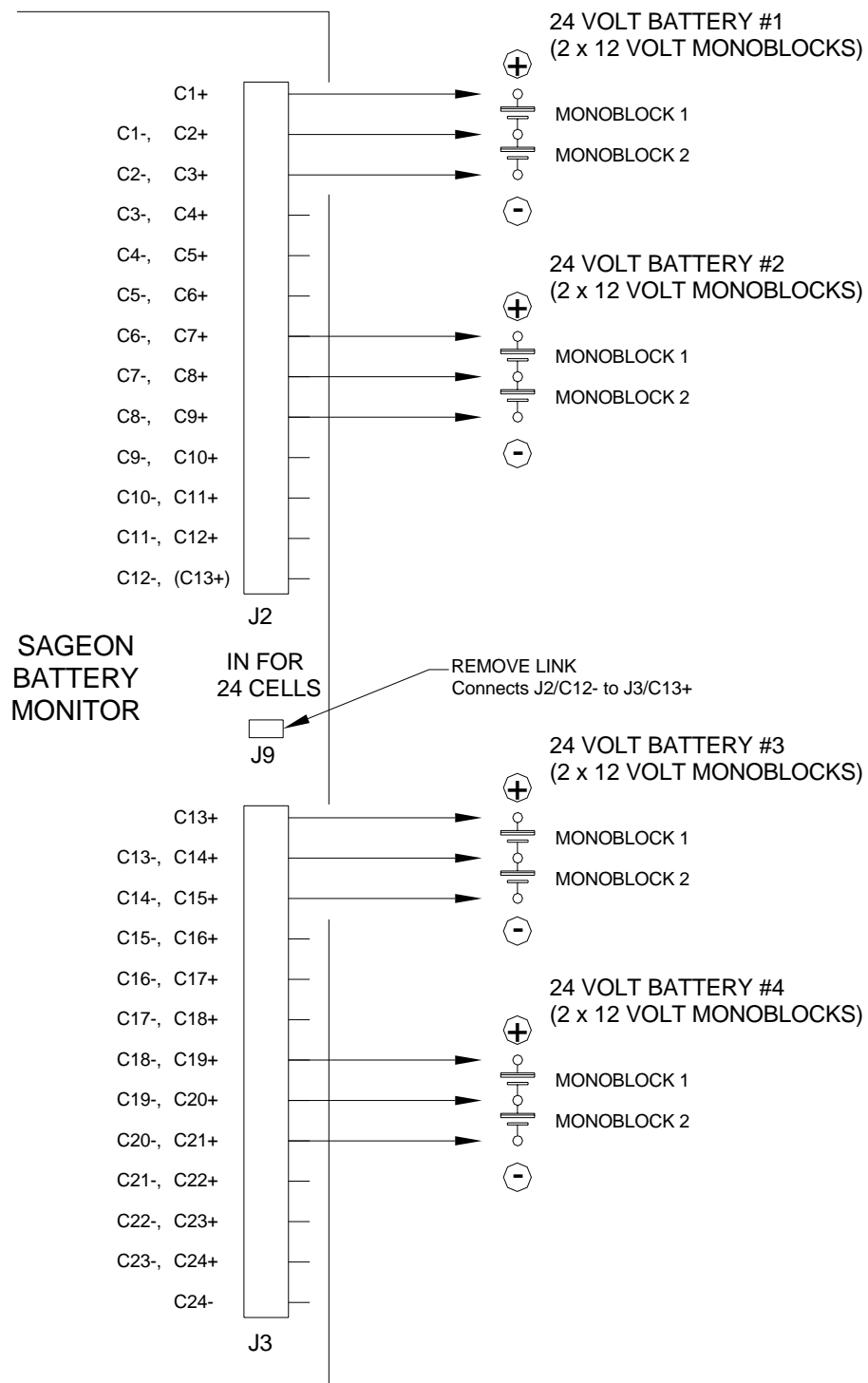

Fig. 11 SBM connections to four 24V (2 monoblock) battery string.

4. Dip-Switch Selection of Cell Voltages

Battery configuration is selected via the main menu of the SCU, whereas the cell or monoblock voltage must be selected via dip-switch “Cell V-Select” on the PCB (S2). The following table indicates the DIP-switch setting for different cell/monoblock voltages:

CELL/MONOBLOCK VOLTAGE	(1)	(2)	(3)
12V	ON	OFF	OFF
6V	OFF	ON	OFF
4V	OFF	OFF	ON
2V	OFF	OFF	OFF

5. Dip-Switch Selection of Address

Each SBM requires a unique address in order for the SCU to know which SBM is connected to which battery string(s). Set the “Unit Address” on each SBM according to the chart below.

SBM	Switch Number 1	Switch Number 2	Switch Number 3	Switch Number 4
First	ON	OFF	OFF	OFF
Second	OFF	ON	OFF	OFF
Third	OFF	OFF	ON	OFF
Fourth	OFF	OFF	OFF	ON

6. System Setup for SBM

6.1. Relationship between “SBM Batteries” and “Num Batteries”

In the next two sections, you will be led through a series of menus to get to the menu of “SBM Batteries”. This is where you define the number of batteries whose cell voltages are to be monitored by the SCU, hence the name “SBM Batteries”. There is no need to program the SCU how many SBM boards are connected. The SCU automatically calculates the number of SBM boards that it requires from the number of “SBM Batteries” that you entered.

Programming Note: Earlier versions of the Sageon Power Plant’s “SCU” referred to the “SBM Batteries” as “BCM Batteries”. Aside from this terminology change, there is no difference of operation of earlier versions.

SAGEON BATTERY MONITOR MANUAL

As an example, consider a 48V system, and you have three battery strings whose cell voltages you would like to monitor, you need to enter 3 for the number of SBM Batteries. You do not need to tell the SCU the number of SBMs that are required. The SCU will automatically calculate the required number of SBMs. The number of SBMs required for different battery configuration is shown in the following table:

Batt Config	SBM Batt = 1	SBM Batt = 2	SBM Batt = 3	SBM Batt = 4
24 cell, 2V	1 SBM	2 SBM	3 SBM	4 SBM
12 cell, 4V	1 SBM	1 SBM	2 SBM	2 SBM
8 cell, 6V	1 SBM	1 SBM	2 SBM	2 SBM
4 cell, 12V	1 SBM	1 SBM	1 SBM	1 SBM
12 cell, 2V	1 SBM	1 SBM	2 SBM	2 SBM
6 cell, 4V	1 SBM	1 SBM	2 SBM	2 SBM
4 cell, 6V	1 SBM	1 SBM	1 SBM	1 SBM
2 cell, 12V	1 SBM	1 SBM	1 SBM	1 SBM

A similar menu but for totally different purposes, appears in the Systems menu as follows:

Num Batteries X (where X is the number of batteries)

The number of batteries entered here is the number of batteries that are being monitored for their currents. “Num Batteries” and “SBM Batteries” are not related except that value entered for “Num Batteries” must be greater or equal to “SBM Batteries”. This is because Num Batteries determines the number of batteries accessible via the BAT menu, via which we access the cell voltages. So if only two batteries are defined for Num Batteries, then you won’t have access to cell voltages of Battery 3 or 4, even if they are defined as 4 in the SBM Batteries menu. Normally Num Batteries is set to be the same as SBM Batteries.

6.2. Battery configuration in 48V and 24V systems

To set up the number of batteries to be monitored by the SCU, in the Systems menu, press DEC key until you see the following menu:

Auxiliary Unit [ENTER]

Press ENTER key, this will get you into the auxiliary options menu, then press INC until the following menu appeared:

Battery Monitor [ENTER]

Press ENTER key, then press INC until you see the following menu

Battery Configuration XXXXX (battery configuration selection)

Press ENTER key to change the battery configuration and the INC, DEC to scroll through the available options, the press ENTER key to program the SCU to the desired configuration. Press INC key again until you see the following menu,

SBM Batteries X (where X is the number of battery strings to be monitored)

This value can be adjusted between 1 to 4.

The number of cells is already fixed by the battery configuration and is not user adjustable except for 24cell/2V configuration. To modify this parameter, press the BATT button on the SCU. This puts you into the Battery Menu. Press INC until the following menu is reached:

Num Cells X (where X is the number of cells to be entered)

This number is adjustable from 22 to 24 for the 24cell/2V configuration. In other cell configurations, this menu is still accessible, but it is not adjustable. Although the number of cells is still displayed in this menu, it is ignored by the system.

6.3. Battery Current Sensor Enable/Disable

If you intend to use the SBM in a system which is equipped with battery current transducers, the menu option “Bat Current Sensor” must be enabled.

6.4. Battery Monitor On/Off

If for any reason, the operator wishes to switch the battery monitor on or off, the can be done locally or remotely. Refer to the Menu structure in the next section for location of this menu.

7. Operational Setup for SBM

7.1. SCU menu structure for Sageon Battery Monitor

The structure of the menu related to Sageon Battery Monitor systems and operational setup is illustrated below:

[SYSTEM Menu]

- Num Batteries X (Where X is the number of batteries monitored for their current.)
(this number must be greater or equal to the number of SBM Batteries)
- Auxiliary Unit [ENTER]
 - ↳ Battery Monitor
 - ↓
 - Battery Monitor (ON/OFF)
 - Battery Configuration XXxXV (XXxXV batt config)
 - SBM Batteries (1,2,3,4)
 - Cell Vhi (1.30V ~ 16.00V)
 - Cell Vlow (0.50V ~ 12.00V)
 - Cell dV+ (1% ~ 99%)
 - Cell dV- (1% ~ 99%)

[BATT Menu]

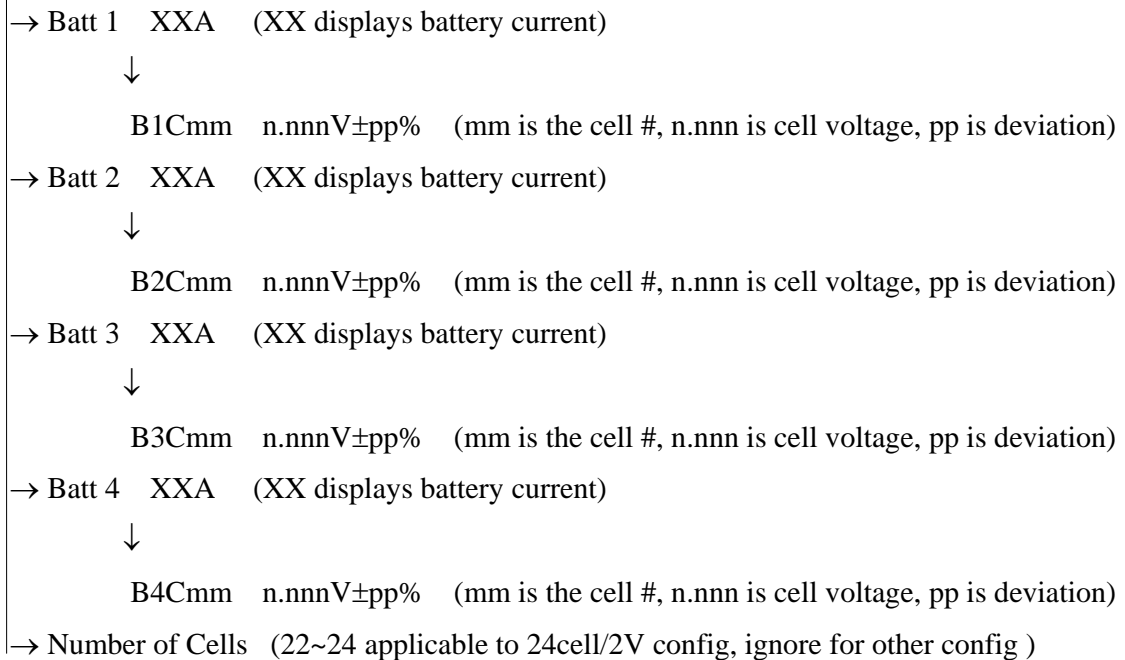

In the above diagram, menu items not related to Sageon Battery Monitor are not listed.

7.2. Frequency of measurement.

To allow for a wide battery capacity range, which can range from 10 minutes to 8 hours, the cell voltage polling frequency is programmable in 1-minute increments. A typical polling interval is 4 minutes, which would yield 15 points for a 1-hour discharge. For programmed test discharge of 30 minutes a polling interval of 2 minutes might be used. This parameter is not accessible from the SCU front panel. It is only programmable from the PC running Sageview.

7.3. Low/High cell voltage alarm

Each cell voltage is compared with a programmed absolute cell low voltage value **Vlow** and high voltage value **Vhigh** and an alarm generated if any cell voltage is lower or higher than this value. The alarm generated is “Cell V High/Low”, High or Low displayed as appropriate.

The two levels are programmed using the following menu windows:

“Cell Vlow..Y.YYV”
“Cell Vhi....Y.YYV”

where Y.YY (or YY.Y for 12V monoblocks) is the cell voltage threshold level

7.4. Cell voltage deviation alarm

Each cell voltage is compared to the average cell voltage for the battery and if the difference is outside of the pre-programmed value $\pm dV_c$ (independent of cell volts high/low alarm discussed in previous section), an alarm is generated - "Cell %dev High/Low" (High or Low displayed as appropriate).

" $+dV_c$ cell...XX%"

" $-dV_c$ cell....XX%"

where XX is the allowable % voltage deviation
from the average cell voltage

8. Processing of cell voltage information

8.1. Storage of battery discharge information.

During a discharge and when no PC is in connection with the SCU, the SCU collects several samples before transferring the information to a PC. For SBM boards, enough memory space is pre-allocated for 4 samples of cell voltages and battery currents of 4 batteries. They are stored in the SCU first before attempting to connect to a designated PC. Since memory is already allocated before hand. The SCU will still need to dump the data onto a PC after 4 samples even if less than 4 batteries are used.

If during a discharge, the PC is connected to the SCU (and not in standby), each sample taken at the end of each polling period will be transferred to the PC immediately, and will not be stored in the SCU.

The role of the SCU with respect to the Sageon Battery Monitor is to collect all the necessary information, and make sure they are within the limits set by the operator. It however cannot store historical data of the battery condition. So the collection of historical data and the analysis is all done on a PC. An export facility is also available in the Sageview program to convert this information to CSV format that can be imported to another database program for further analysis.

Note: The word *sample* here is defined as collection of all the cell voltages and battery currents at a particular instant of time, i.e. end of a polling period, also included are the temperature of the batteries.

8.2. Information available via the SCU VFD display

Since the SCU does not contain historical information of the battery status, the user can only see the battery status at that instant. These are cell voltages and their deviation from other cells, battery current and temperature.

To observe the cell voltage for each cell of each of the battery banks together with its deviation from the average cell voltage Value, press ENTER after scrolling to the current display for a particular battery e.g. "Batt 1 35A". After pressing ENTER the display then shows the following:

"B1C14 2.235V+03%"

Where B1 represents battery string 1, C14 represents cell #14, 2.235 is the cell voltage and +03% is the percentage variation from the average cell voltage for the battery. Clearly, the deviation may also be negative (-).

Pressing ENTER again returns the display to the beginning “B1 35A” of the submenu. It is then possible to scroll (INC) to “B2 37A” display and by pressing ENTER the individual cell voltages for battery 2 can be observed.

8.3. Information available on the PC

Sageview is a program that is used on the PC to monitor and control SCUs. A considerable amount of information can be display conveniently on a PC. It includes real time battery status if the PC is connected to a system locally or remotely. If a discharge is in progress, the discharge progress is stored on the PC for the entire period of the discharge. These collected data are stored automatically on the PC and can be recalled later. They can also be exported via CSV format to other programs, for example, Excel, where more sophisticated mathematical tools are available.

For more information on battery related functions of the Sageview, refer to the Sageon product manual.

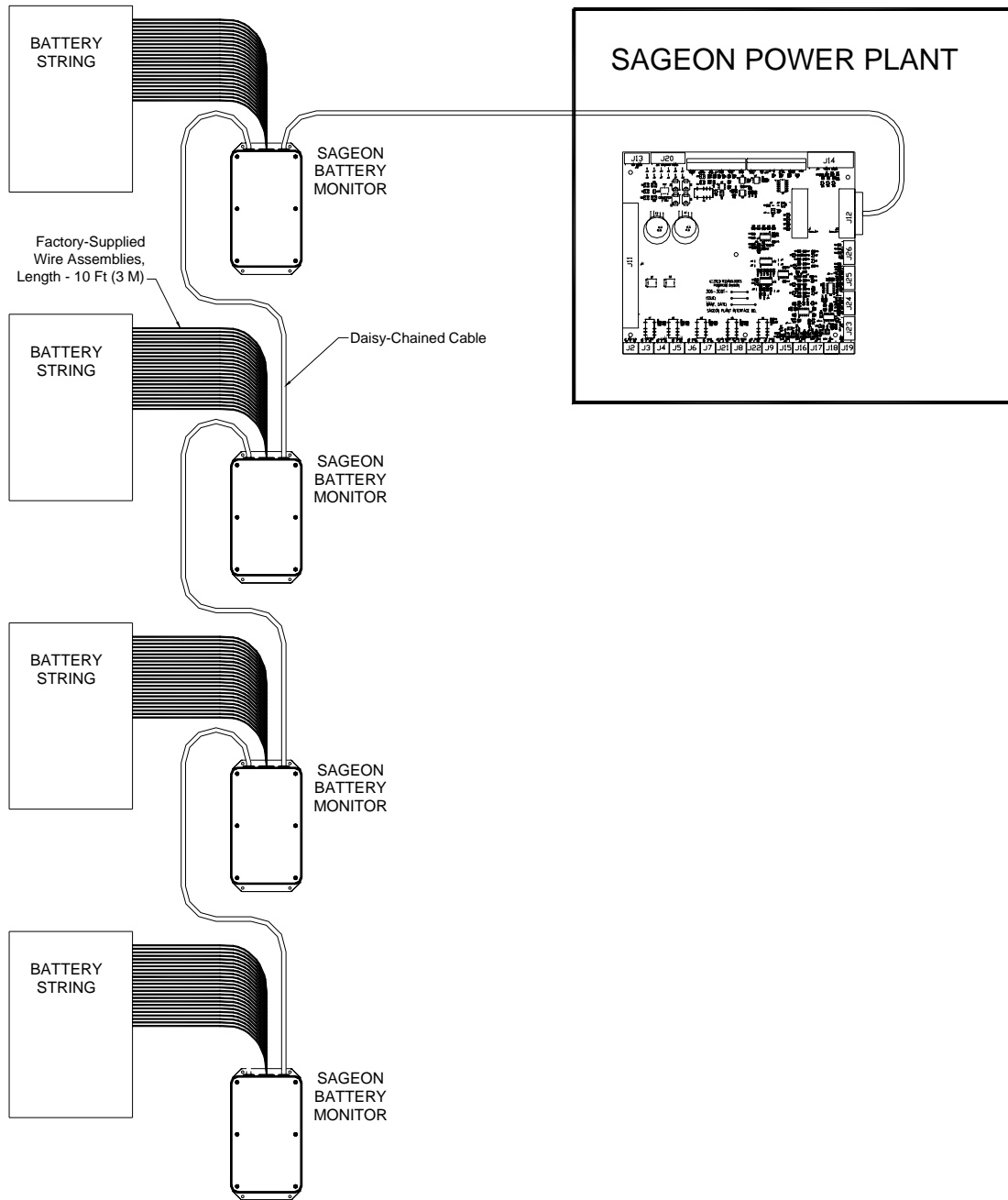

Fig.12 Typical 48V, four battery system.